

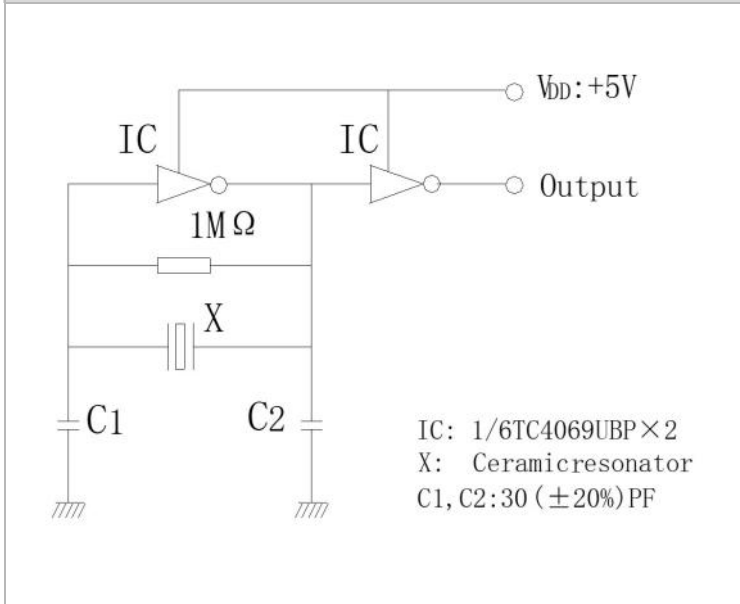

■ TEST CIRCUIT

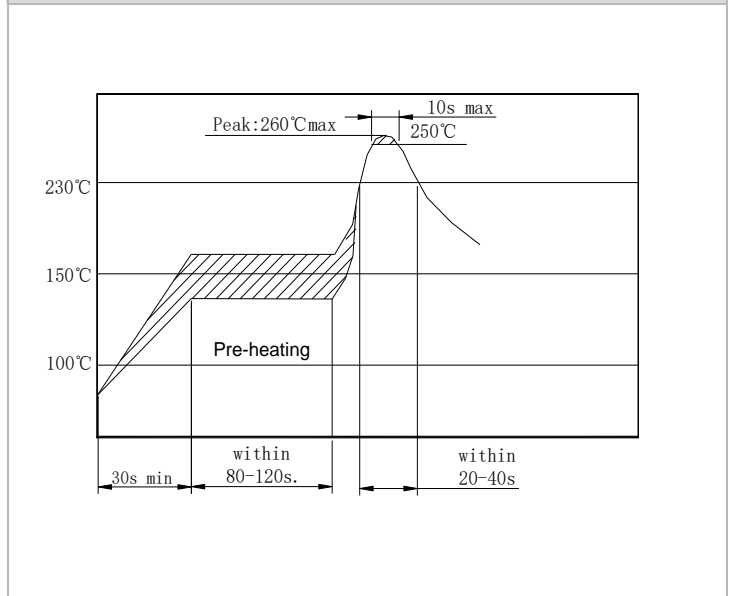

■ REFLOW PROFILE



■ PART NUMBERING GUIDE

