

ULTRA MINIATURE SMD HCSL OUTPUT OSCILLATOR (5.0 x 3.2 x 1.3mm)

FEATURES:

- LOW PHASE NOISE
- RoHS COMPLIANT
- HCSL OUTPUT



■ SPECIFICATION

FREQUENCY RANGE		13.500MHz ~ 160.000MHz
FREQUENCY STABILITY		±20ppm ~ ±100ppm
OPERATING TEMPERATURE RANGE		STD: -20°C ~ 70°C, Option: -40°C ~ 85°C (See P/N guide for other options)
STORAGE TEMPERATURE RANGE		-55°C ~ 125°C
SUPPLY VOLTAGE ± 5%		1.8V _{DC} , 2.5V _{DC} , 3.3V _{DC}
SUPPLY CURRENT		40mA max.
OUTPUT	LOGIC FAMILY	HCSL square wave
	LOAD	50Ω (Between output and GND)
	LEVEL LOGIC '1' (V_{OH})	900mV max.
	LEVEL LOGIC '0' (V_{OL})	-150mV min.
	SYMMETRY(DUTY CYCLE)	45% / 55%
	RISE AND FALL TIME (Tr/Tf)	1.0 nS max.
STAND-BY VOLTAGE	ENABLE (V_{IH})	0.7 x V _{DD} ≤ V _{IH} ≤ V _{DD} or N/C
	DISABLE (V_{IL})	V _{IL} ≤ 0.3 x V _{DD}
STAND-BY CURRENT		10μA max.
AGING @ 25°C ± 3°C		±3.0ppm / year max.
PHASE JITTER RMS		1.0ps. max.
PHASE NOISE @ (100MHz OFFSET)		-74dBC/Hz Typ. @10HZ -106dBC/Hz Typ. @100 HZ -130dBC/Hz Typ. @1KHZ -143dBC/Hz Typ. @10KHZ -148dBC/Hz Typ. @100KHZ -153dBC/Hz Typ. @1MHZ -158dBC/Hz Typ. @10MHZ

■ PACKAGE DIMENSIONS

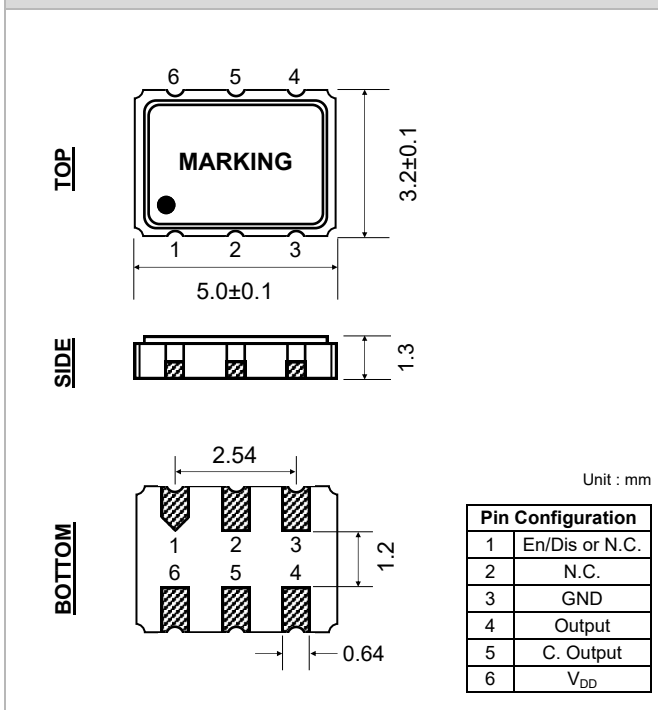

■ REFLOW PROFILE

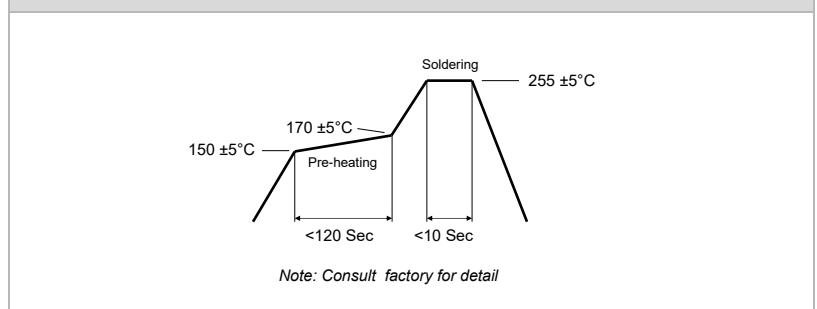

■ PART NUMBERING GUIDE

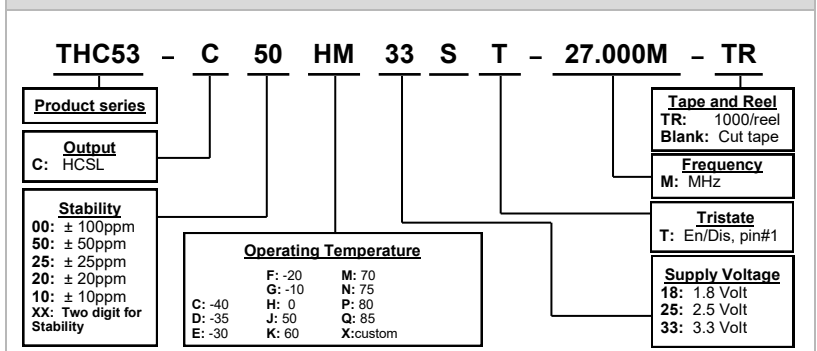

Transko Electronics, Inc reserves the right to make changes to the product (s), service (s), and specification (s) described herein without notice. See "Terms of Sale" for details on our website.