

Power Inductor SMD (6.7 X 6.7 X 4.0mm)

FEATURES

- Magnetic shielded
- Halogen Free RoHS compliant
- AEC-Q200 qualified



SPECIFICATION

Part No.	Inductance (μH)	Tolerance (%)	DC Resistance (Ω) Max.	Rated DC Current (A) Max.
TPRH6D38Q1F-3R3N	3.3	± 30	0.02	3.50

- Rated current: Min (Isat, Irms); Isat: 35% drop typ; Irms: $\Delta T=40^\circ\text{C}$ typ. At 25°C
- Measurement frequency of Inductance value : at 100KHz, 0.25V
- Test equipment: CH1062A / CH1320

DIMENSION

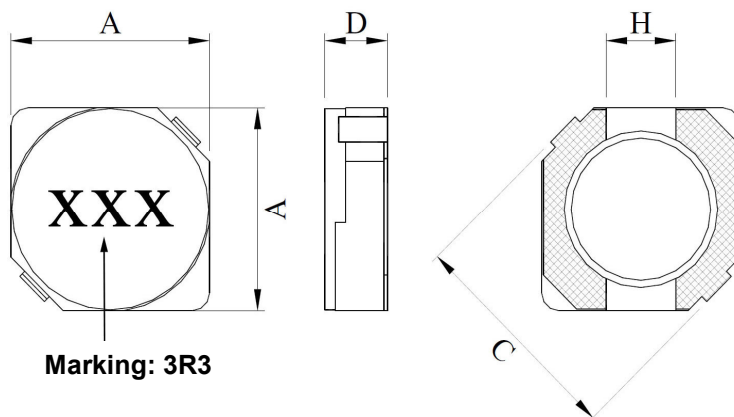

SOLDER PATTERN

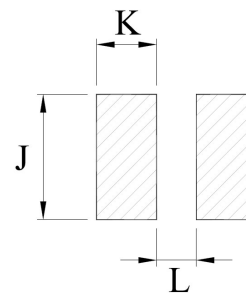

SCHEMATIC

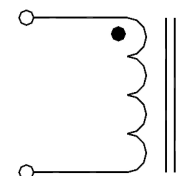

	A	D	C	H	J	K	L
mm	6.70 ± 0.30	4.00 Max	9.50 TYP	2.00 REF	7.30 REF	2.65 REF	2.00 REF

LEAD-FREE HEAT ENDURANCE TEST

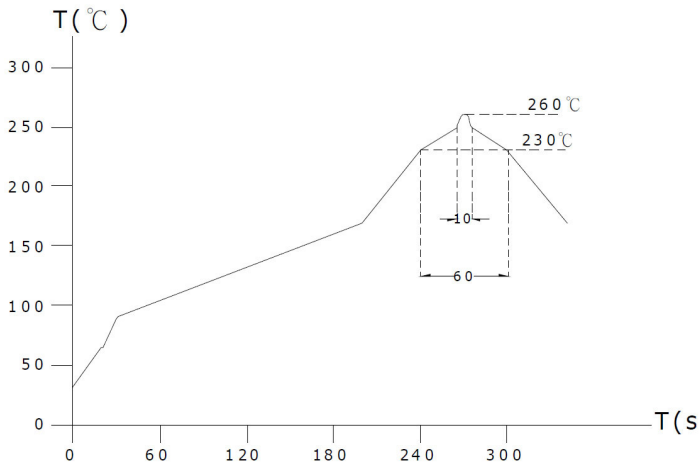

LEAD-FREE RECOMMENDED REFLOW

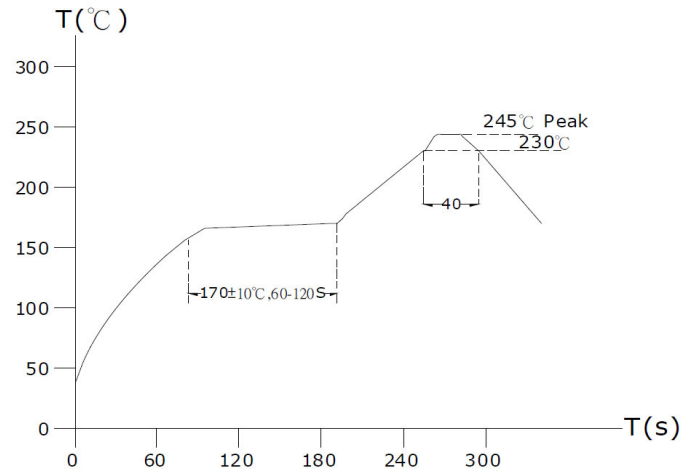

REEL DIMENSIONS (1000 pcs per reel)

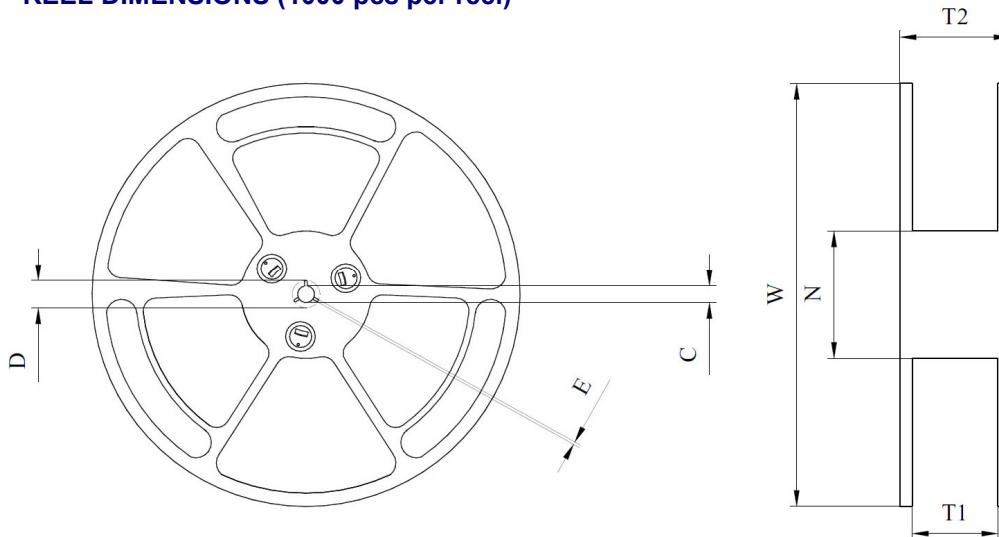

	mm
W	330±1.5
D	21.5+0.5/-0
C	13+0.5/-0.2
T1	16.5+0.5/-0
N	100±1.5
T2	21.4±0.4
E	2.00±0.5

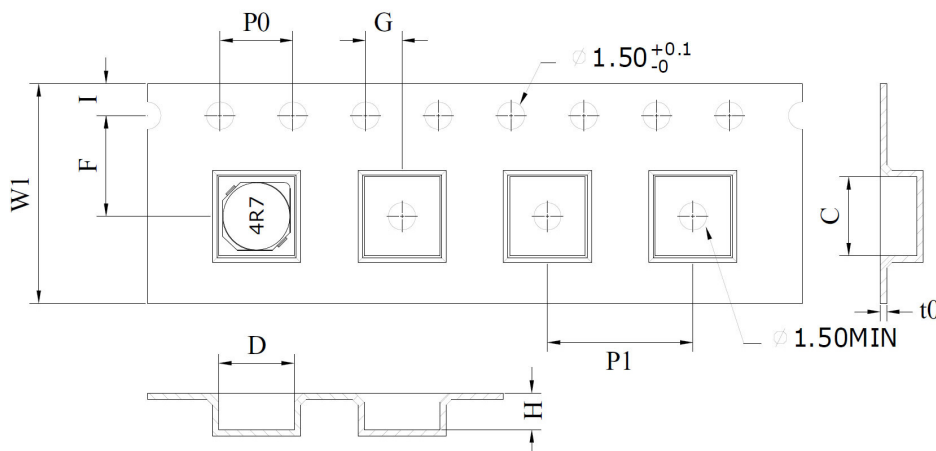

	mm
W1	16.00±0.3
I	1.75±0.1
F	7.50±0.1
P0	4.00±0.1
G	2.00±0.1
P1	12.00±0.1
C	7.60±0.1
t0	0.35±0.05
D	7.60±0.1
H	4.2±0.1

RELIABILITY TEST

1. Operating temperature range
-40°C to +125°C (Includes temperature when the coil is heated)
2. High temperature exposure (storage) refer MIL-STD-202 Method 108:
1000 hrs at rated operating temperature (e.g. 125°C).
Part can be stored for 1000 hrs @125°C. Unpowered.
Measurement at 24±4 hours after test conclusion.
3. Temperature cycling refer JESD22 Method JA-104:
1000 cycles(-40°C TO +125°C) Measurement at 24±4 hours after test conclusion.
30 min maximum dwell time at each temp. extreme. 1 min. maximum transition time.
4. Biased Humidity refer MIL-STD-202 Method 103:
1000 hours 85°C /85%RH. Unpowered. Measurement at 24±4 hours after test conclusion.
5. Operational Life refer MIL-PRF-27:
1000 hrs. at 125°C tested. Measurement at 24±4 hours after test conclusion.
6. External Visual refer MIL-STD-883 Method 2009:
Inspect device construction, marking and workmanship.
7. Physical Dimension refer JESD22 Method JB-100:
Verify physical dimensions to the applicable device detail specification.
8. Resistance to Solvents refer MIL-STD-202 Method 215:
Add aqueous wash chemical - OKEM clean or equivalent.
9. Mechanical Shock refer MIL-STD-202 Method 213:
Figure 1 of Method 213. Condition C.
10. Vibration refer MIL-STD-202 Method 204:
5g's for 20 minutes, 12 cycles each of 3 orientations. Test from 10-2000 Hz.
11. Resistance to soldering Heat refer MIL-STD-202 Method 210:
Condition B No pre-heat of samples. Single wave solder - procedure 2 for SMD and procedure 1 for leaded with solder within 1.5mm of device body.
12. ESD refer AEC-Q200-002 or ISO/DIS 10605:
Direct contact discharge 2kV.
13. Solderability refer J-STD-002: For SMD. Magnification 50X. Conditions:
SMD a) Method B, 4hrs@155°C dry heat @235°C ,
b) Method B @215°C category 3.,
c) Method D category 3@260°C
14. Electrical Characterization refer spec:
Show Min, Max, Mean, and Standard deviation at room from Min and Max temperature.
15. Flammability refer UL-94: V-0 or V-1 Acceptable.
16. Board Flex refer AEC-Q200-005: 60 sec minimum holding time.
17. Terminal Strength(SMD) refer AEC-Q200-006
18. Storage environment: MSL II
Storage condition: Temperature Range: 0°C ~ 35°C ; -45°C ~ 125°C (after PCB)
Humidity Range: 50% ~ 70% RH
19. Use components within 12 months.
If 12 months or more have elapsed, check solderability before use.